



## MOTORIZED ADJUSTABLE WALL MOUNT

Classroom technology should not be limited to just a few. ConenMounts motorized Wall Mount Light<sup>™</sup> provides 20" of height adjustment, providing teachers and students an optimum ergonomic and writing position and enabling even those in early grades or in wheelchair to participate.

The wall mount supports 55" – 86" flat panel displays and works by a simple, push-button operation.

Because the weight of the display is distributed to the floor, the wall mount allows for the display to be mounted to any type of wall, without the need for reinforcement, and allows mounting over existing boards.

The system is maintenance-free, complies with the requirements of the ADA standards and is backed by a 5 year warranty.

### Key features

- 20" of smooth, motorized height adjustment
- Mounts to any wall and over existing whiteboards
- Supports 55" – 86" displays
- Complies with IEC/UL 62368-1 standard
- Laptop shelf optionally available
- Maintenance free
- Quick and easy mounting
- 5 year limited warranty

## Technical drawings

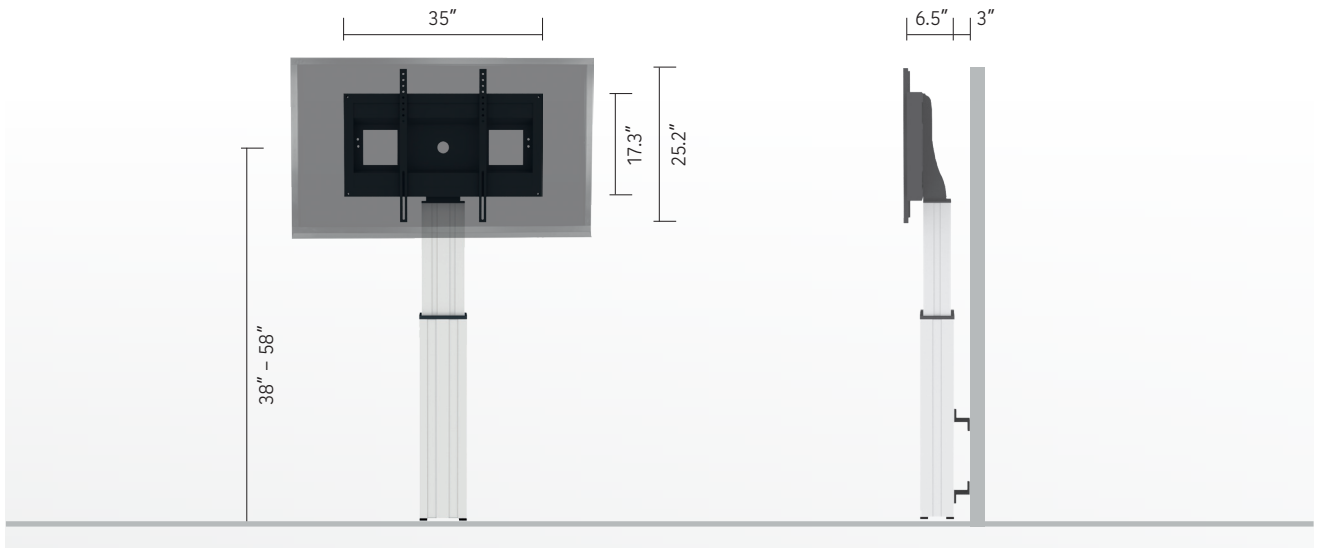

Product Code	SCETAWL
Display range	55" - 86"
VESA pattern	up to 800 x 600
Load capacity	300 lbs
Shipping weight	75 lbs
Warranty	5 year



Levelling feet and 2 wall mounting brackets for optimum stability



Pull & release locking brackets for easier mounting of display



Wired remote control included

## Available accessories



Front shelf

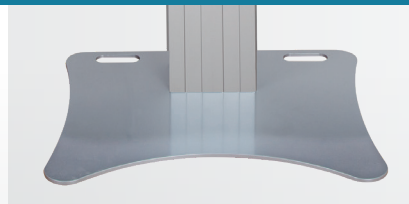

Floor plate



Stud wall mounting bracket

**CONEN**<sup>®</sup>  
*mounts*

### Distributed by:

Stirling Communications Supply  
29 Poplar Drive  
Stirling, NJ 07980

T: (908) 604-9360  
E: DPilar@stirlingcomm.com  
[www.conenusa.com](http://www.conenusa.com)